

GQW101

Automatic Stretch Wrapper 全自動預拉膠膜機



Online Video

Key Features

- PLC with the inverter controls motor.
- Patented clamp-film / stick-film mechanism for automatic process to reduce working time.
- Remote start to save the operator's time to go back and forth from the forklift.
- It can stick the film tails directly. The film tails won't peel off and the wrapping finishing is tight and tidy.
- The turntable is driven by the belt, which makes it turning in no noise, stable and smooth.
- The film carriage has the patented anti-drop device to ensure safety.
- The speed of the turntable and the film carriage can be adjusted by the inverter.
- The turntable has soft start / stop to ensure safety.
- Fast film loading.
- The turntable can be positioned to the origin automatically.
- It can be switched to manual or auto mode.
- Controlled by touch screen (HMI / MMI).

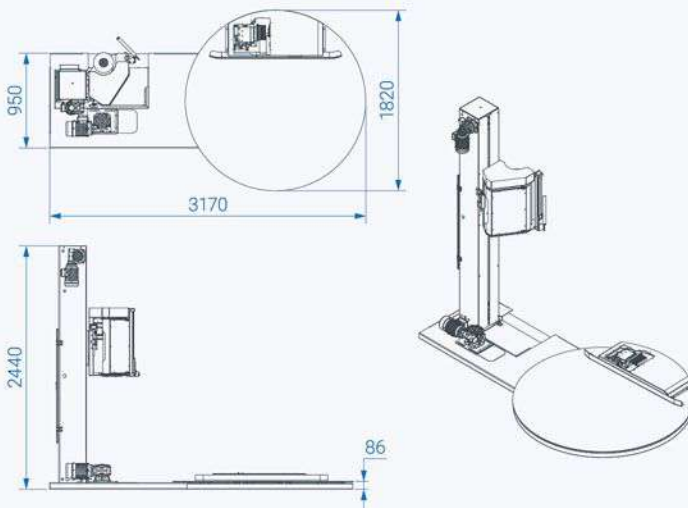

特性

- PLC 程式控制，搭配變頻器控制馬達。
- 專利夾膜/黏膜機構，流程自動化，縮短作業時間。
- 可遙控啟動，省下操作人員往返堆高機時間。
- 機器黏膜，膜尾在運送中不易脫落，裹包緊實又整潔。
- 皮帶式轉盤傳動，轉動無噪音、平穩順暢。
- 專利防墜裝置，保障使用安全。
- 轉盤及膠膜座速度，可無段變頻調整。
- 轉盤具和緩啟動/停止功能，確保產品安全。
- 膠膜快速穿膜設計。
- 轉盤具原點定位功能。
- 可切換手動/自動操作模式。
- 觸控式面板控制。

Machine Size	Turntable Dia.	Turntable Height	Optional	Applicable Film	
機械尺寸	轉盤直徑	轉盤高度	選配	適用膠膜	
L3220 × W1810 × H2440 mm Spec. subject to change without prior notice. 機台尺寸以實際製作為準	1800 mm Optional: Customized size is available. 可訂製加大	86 mm	Ramp 斜拖板	PE 20~30μ	
Film Pre-Stretch	Max. Load Weight	Max. Wrap Height	Film Carriage Speed	Turntable Speed	Voltage
膠膜預拉	乘載重量	裹包高度	昇降速度	轉盤速度	電壓
200% Standard. 標準	1500 kg Optional: 2000 kg 可選購：2000 kg	2000 mm	3 M/min Adjustable. 可調	12 RPM Adjustable. 可調	1Φ, 220V Depend on customer's request. 可依客戶需求指定